

CMC Controls Ltd - The Tension Control Specialists

LETIX Digital Web Tension Indicator



The LETIX Digital Web Tension Indicator continuously displays the true web tension either as a percentage of total tension or in real engineering units.

The measurement of actual web tension is made by sensing, with strain gauge transducers (sometimes referred to as 'load cells'), the force on a sensing roller caused by the tension in the web. The electrical signal from the transducers is a combination of tension force and sensing roller deadweight.

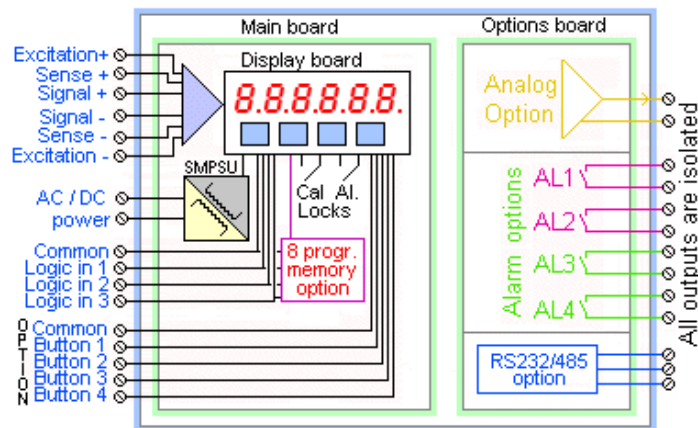

The effect of the weight of the sensing roller is removed electrically, leaving the tension force signal only to be displayed on the meter.

The LETIX indicator uses high specification A/D and D/A converters, power supply, and a bright LED digital display, all housed in a standard DIN size case. The LETIX features as standard a transducer bridge supply excitation of 5v (or 10v) DC, an independently scalable digital display and an isolated analogue output (0 to +10V at 2 mA maximum). It can be used as a remote display and/or as the input to a control system.

The Indicator can accept full scale input voltages of either up to +/- 40 mV (foil strain gauges) or up to +/- 400 mV (semi-conductor strain gauges) for full display with selectable decimal point position and scaling, and a zero offset for both positive and negative sensing.

Installation



The Indicator must be installed in a dry, non-hazardous location.

A panel cut out of 92 mm (+1.0/-0.0 mm) x 45 mm (+1.0/-0.0 mm) is required. The depth of the Indicator is 125 mm but extra provision must be allowed for cable connections. A single fixing clip, behind the unit, retains the Indicator. To install, simply insert the Indicator into the cut out and fit the clip to hold the Indicator in place.

The tension transducers must be installed in accordance with the installation procedure from the transducer handbook. See the transducer part of the handbook or a specific drawing for the connection details and wire colours.

Mains Supply Voltage Selection

The LETIX is available in two power supply options, which are specified and fitted by CMC before despatch according to the clients' needs. Either: -

- 1) AC mains supply 110-230 v universal. This has a RED main connector.
The supply **MUST** be via a 400mA Antisurge fuse, or similar, with a local MCB or isolator.

OR

- 2) DC supply 11-30v DC. This has a BLACK supply connector.
The supply **MUST** be via a 2 Amp Antisurge fuse, or similar, with a local MCB or isolator.

PLEASE NOTE:

This unit is **not** fitted with a safety earth terminal. The protective Earth supply of the AC Mains and the screens of the transducers, and any other cable, should be bonded to earth locally with short leads.

Indicator Calibration

This is usually pre set by CMC to the clients needs before despatch, but final calibration will always need to be done on site, with the correct tension, wrap angle, roller, and transducers according to their application.

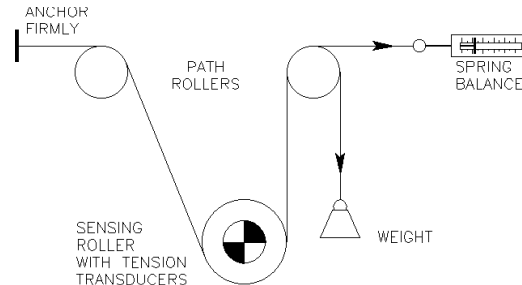

To calibrate the LETIX indicator correctly a spring balance (or weights) to provide the required tension force and some flat strapping or similar to simulate the web will be needed.

Connect the transducers correctly, and apply power to the unit. After a few seconds, it will go through the start up routine. It is a good idea to leave the power on for 10-15 minutes to allow the transducers to settle.

Do not at this stage adjust the scale, as usually this has been factory set ready for calibration purposes. The final display scaling can be adjusted later.

IMPORTANT

Before calibration, ensure that the dipswitches at the rear of the unit are set to the **UP** position. After calibration, set them to the **DOWN** position. This will stop the machine operator from altering the settings and prevent re-calibration of the indicator.

With the strapping in the machine along the correct web path (as shown in the diagram), pull the maximum tension value.

Press the "**SET 2**" button for three seconds. The display will show "direct", followed by "Set Hi". Press "**OK**".

Press the "**SET 2**" button again for three seconds. You can now set the decimal place position with the "**UP**" or "**DOWN**" buttons. Press "**OK**" when done.

You can now set the display value you want to see. Use the "**DIGIT**" button to select each digit in turn and the "**UP**" and "**DOWN**" buttons to increase or decrease each digit's value, as needed (for example 1500.0). Then press "**OK**" to save.

The next step is to remove the web tension. Then press the button marked "**SET 1**" for three seconds until the display reads "direct" and then reads "Set Lo". Press "**OK**". The digits will all display 00000.0, then press "**OK**" again for display to read (for example 0.0).

The calibration is now finished, and the tension indicator should read correctly.

Output Signal Calibration

Once the tension calibration has been done, it is important that the analogue output signal (normally 0/10v = 0/100% tension) is correctly set to match the calibrated scale. Unless otherwise ordered, the indicators are shipped from CMC Controls with the output signal set to 100.0 (%) = 10.0v. Should other ranges be required, it is quite simple to alter: -

After calibrating the equipment, remove the web tension. Press the "**OUTPUT**" button for three seconds. The display will show "OUTPUT" followed by "0-10v", then "net". Press "**OK**". The display will now show "Out Lo" and the 0% LED will flash. Display will show 0.0 (= 0% tension). Press "**OK**" when done.

The display now shows "Out Hi" and the 100% LED will flash. Use the "**DIGIT**" button and "**UP**" and "**DOWN**" front panel push buttons to set the displayed value to equal the maximum tension value (for example 1500.0). Press "**OK**" when done.

The output signal from terminals 14 & 15 should now be 0/10.0v = 0/100% of the maximum tension. **Please Note** that the digital display will read numbers above the maximum calibrated value, but the output will be limited to about 10.3v above the maximum tension value.

IMPORTANT Once this has been done, set the dipswitches at the rear of the unit to the **DOWN** position. This will stop the machine operator from altering the settings and prevent re-calibration of the indicator.

Simple Troubleshooting

- [1] Is the digital display illuminated when the Indicator is switched on?
If not, check the incoming mains supply and fuse.
(There are no internal fuses which can be replaced)
- [2] Measure the transducer excitation supply voltage between terminals (negative) 1 & 2 (linked) and between positive 5 & 6 (linked) and that it is correct for the type of transducer. (5v for Cleveland Kidder Classic and Ultra series, and 10v for foil type transducers). In addition, measure the differential millivolt signal at full transducer load to ensure that the unit is given signals within its correct working range.
- [3] Is the display reading correctly when the transducers are loaded?
If not, check the wiring connections to the transducers, interconnecting cables, and mechanical mounting of the transducers.

Check the resistance values of the transducers, as explained in the transducer section of the handbook.

Zener Barriers (if fitted) may also need to be checked that they are correct.

- [4] Try the re-calibration procedure above.

NOTE that this unit CANNOT be repaired in the field, and must be returned to CMC Controls Ltd.

- [5] An exchange unit is available from CMC Controls Ltd.
Contact the service department. Notify them of your problem, and a spare Indicator can be despatched against your order number and the returned Indicator repaired (or credited if found faulty under warranty).

Connections for Cleveland-Kidder Classic Semi-Conductor Transducers (Two Half-Bridge Transducers)

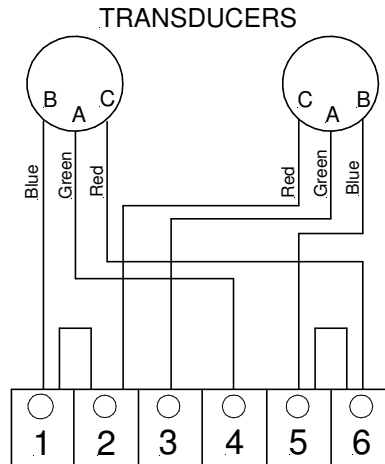

PLEASE NOTE:

Connect the cable screens (green/yellow) to clean earth close to the LETIX Tension Indicator.