

General Description

The DTAX tension amplifier is a compact signal conditioning amplifier designed for use with any of the CMC Controls Ltd range of tension transducers.

The measurement of actual web tension is made by sensing, with strain gauge transducers, (sometimes referred to as 'load cells'), the force on a sensing roller caused by the tension in the web. The electrical signal from the transducer is a combination of tension force and roller deadweight. The deadweight of the sensing roller is zeroed out electrically, leaving only the tension force to be displayed on a meter.

The DTAX requires an external 24V d.c. power supply

The DTAX unit uses high specification amplifiers and an integral voltmeter in a DIN rail mounted housing. The DTAX provides transducer excitation of either 5V or 10V d.c., an analogue voltage output (0-10V d.c.) relating to the total tension detected (The sum of the left and right transducers if two transducers are fitted), separate left and right output voltages and 0-20mA or 4-20mA into 250ohms for remote metering or to the input of a control system. There is in addition a dual range facility as standard.

The DTAX has fully variable zero offsets for both positive and negative roller deadweights.

Installation

The DTAX must be installed in a dry, ventilated, non-hazardous location. The housing snaps onto a standard 35mm wide DIN rail [EN50022].

The transducers must be installed in accordance with the procedures from the Transducer Handbook and for Intrinsically Safe installations the transducers must be installed using only the connecting cables with earth bonding conductors, the cable screens connected to earth at the Zener Barrier busbar only. The Zener Barriers MUST be installed as directed in the Zener Barrier Handbook to achieve a safe installation.

Always use screened cable for connecting transducers and analogue outputs. If the cables are extended the screen conductors must be electrically continuous.

Terminal Arrangement

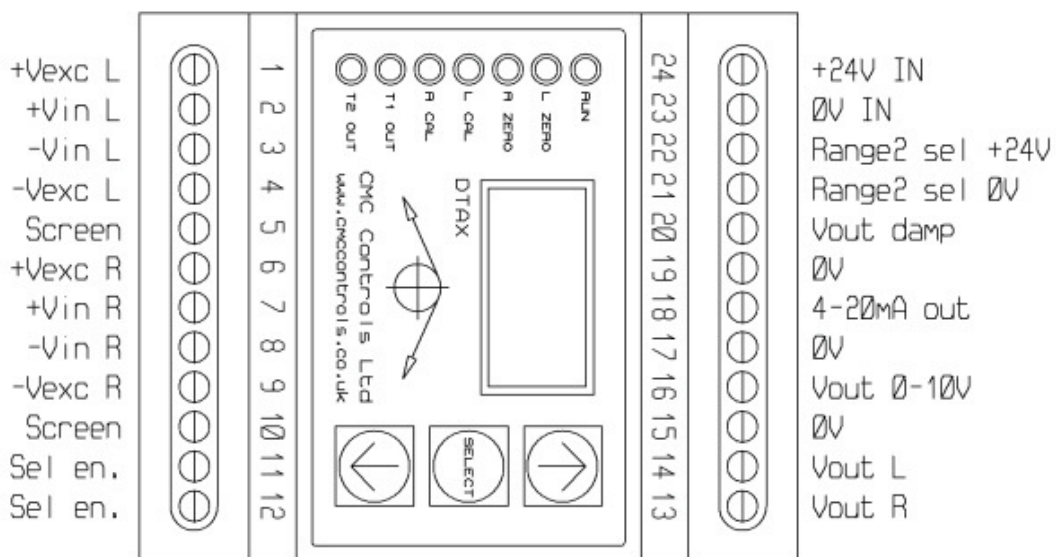

DTAX Dimensions and mounting detail

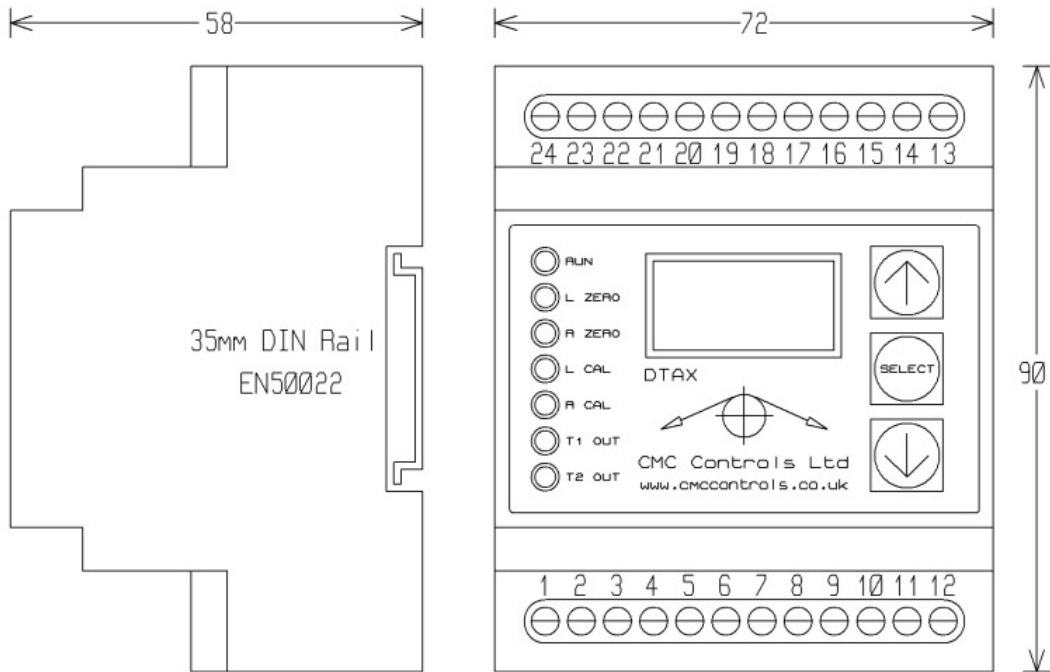

Dimensions:

Width 72mm
 Height 90mm
 Depth 58mm
 Weight 182g

Fixing:

35mm DIN Rail [EN50022]

DTAX/H - Half Bridge Transducer Connections for Safe Area Installations

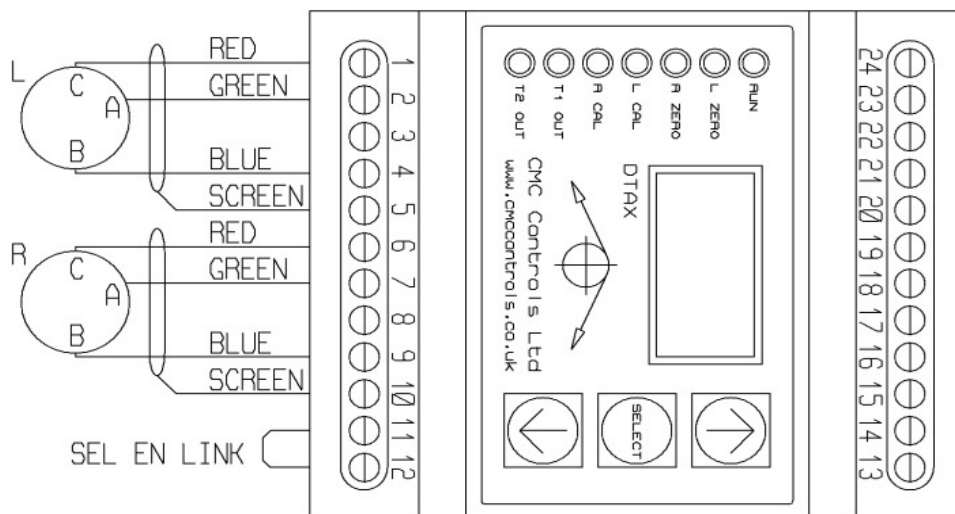

Full Bridge Transducer Connections for Safe Area Installations

Connections for Cleveland Kidder Ultra Transducers

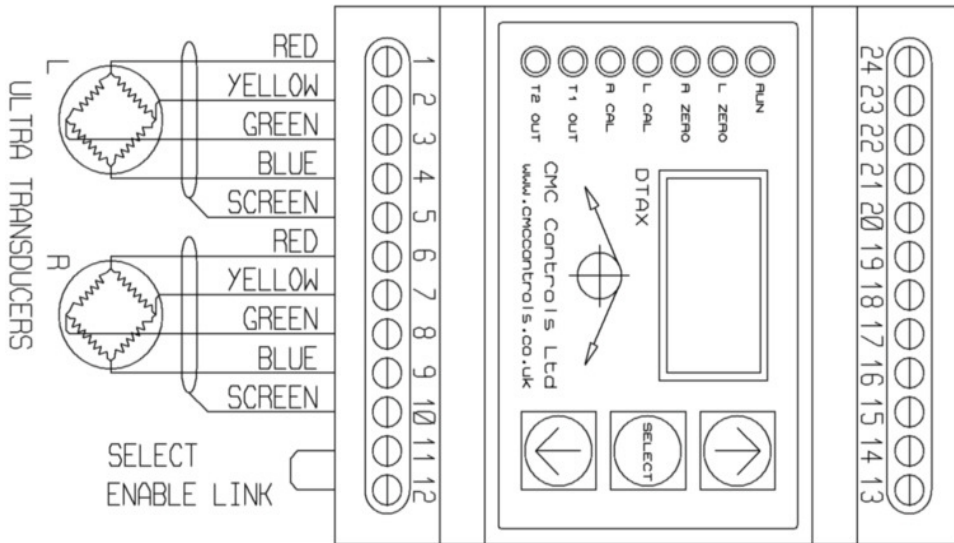

See the Transducer Handbook for alternative CMC Controls Ltd wire colour coding.

Connections for ACDF and Foil Gauged Transducers

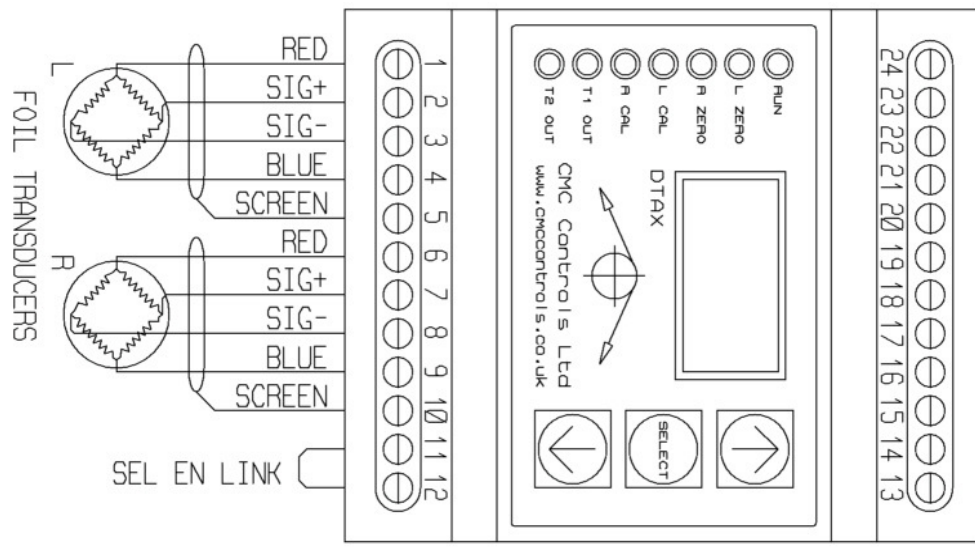

See the Transducer Handbook for the SIG+ and SIG- wire colours

DTAX Calibration

The DTAX will be factory set for an excitation voltage of 5V d.c. for semiconductor transducers, 10V d.c. for foil transducers and the internal gain is factory set according to required transducer type at the time of ordering. Contact CMC Controls Ltd regarding any required changes in transducer type.

To calibrate the DTAX correctly a spring balance or weights to provide the maximum required tension force and some flat webbing or packaging tape to simulate the web would be useful.

Connect the transducers to the DTAX [terminals 1 - 5 for the Left transducer and terminals 6 - 10 for the Right transducer] according to the transducer type.

1. Connect the DTAX to a suitable 24V d.c. supply with +24V to terminal 24 and 0V to terminal 23
2. Connect a 'select enable' wire link between terminals 11 and 12 to enable menu up/down and select membrane switches.
3. Switch on and observe green 'RUN' indicator 'on' and meter display powered
4. Ensure that there is no web material in the machine
5. Press the 'select' button once to step to the 'L Zero' position and adjust the zero multiturn preset located immediately above the left transducer terminals to obtain a reading on the meter as close as possible to 0% (0V)
6. Press the 'select' button once again to step to the 'R Zero' position and adjust the multiturn preset located immediately above the right transducer terminals to obtain a reading on the meter as close as possible to 0% (0V)

Steps 5 and 6 have now removed the effect of the sensing roller deadweight

7. Thread the webbing or tape over the sensing roller following the web path exactly, anchor one end firmly as shown. Do not thread over a non-turning roller, driven roller or machine frame as any sliding friction will cause errors.

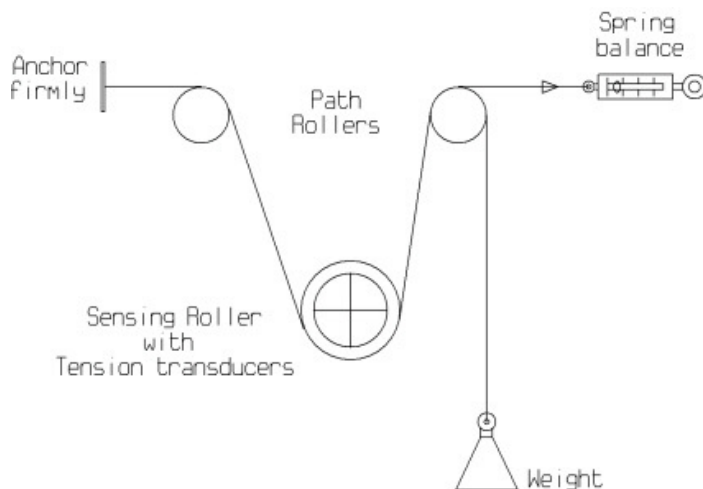

8. Apply the maximum high tension force to the free end of the webbing or tape. If the force is insufficient for the maximum desired value the amplifiers may be calibrated proportionally.
9. Press the 'select' button to step to the 'L Cal' position and adjust the 'up' and 'down' buttons as required to display as close to 100% as possible.
10. Press the 'select' button to step to the 'R Cal' position and adjust the 'up' and 'down' button as required to display as close to 100% as possible.

11. Press the 'select' button to step to the 'T1 Out' position, the display will depict 100% tension corresponding to the accuracy of the 'L Cal' and 'R Cal' settings. The display may be scaled to a required figure by adjusting the 'up' and 'down' buttons to depict the actual tension force.
12. Press the 'select' button to step to the 'T2 Out' position, if a second measurement range is required, reduce the load to simulate the required second range force to the free end of the webbing or tape and adjust the 'up' and 'down' buttons to display as close to 100% as possible.
13. Press the 'select' button to step to the 'Run' position and confirm that the meter reads the first range total output of 100%.
14. To prevent accidental mis-adjustment of the programmed settings remove the 'select enable' link from terminals 11 and 12, this will disable the 'select', 'up' and 'down' buttons.

DTAX Power and Metering connections

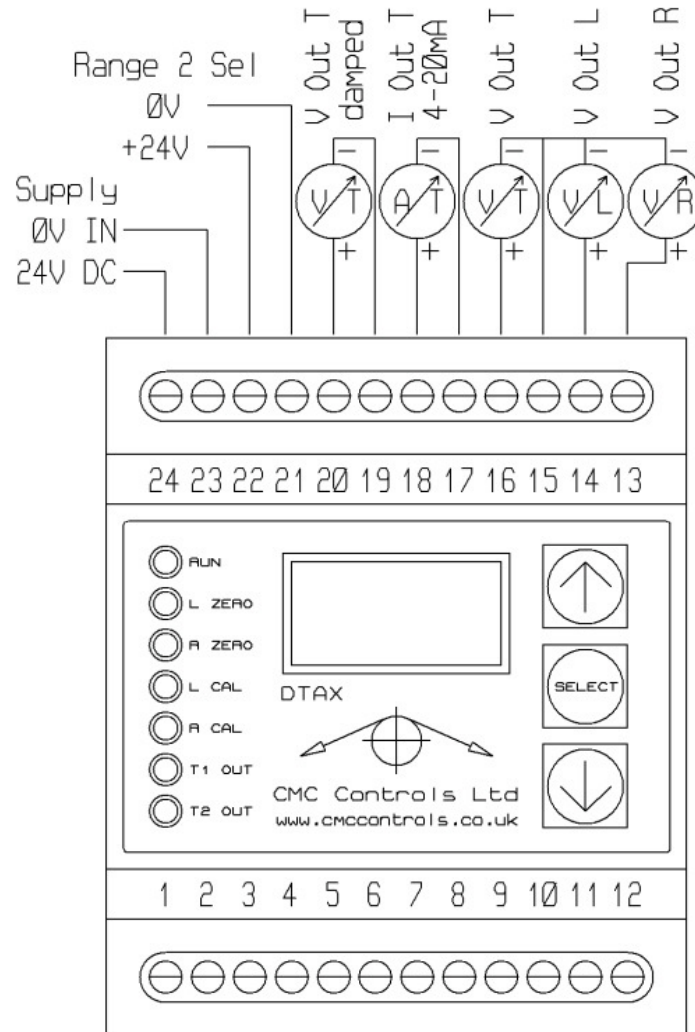

External meters to read 0 to +10V full scale can be supplied by CMC Controls Ltd or an alternative method of displaying the tension values can be provided by the user.

The voltage outputs could alternatively be connected to a programmable logic unit [PLC] for signal conditioning and logic control.